

**NAME: STEERING BRAKE KIT
FOR 5000 SERIES TRACTORS**

PART NUMBER(S): 23378

These instructions give the procedure for installing the Steering Brake Kit on the 5000 Series Tractors. Any reference to right side, left side, front and rear are given from the operator's position. Tighten the bolts used to install the Steering Brake Kit to the torque given in the Bolt Torque Specifications unless shown differently.

BOLT SIZE	BOLT TORQUE SPECIFICATIONS	
	FOOT POUNDS (ft. lbs.)	NEWTON METERS (N.m)
1/4"	7	9.5
5/16"	14	19
3/8"	25	34
7/16"	40	54
1/2"	60	82
9/16"	83	113
5/8"	120	163
3/4"	200	271

1.0 HOW TO INSTALL THE BRAKE HANDLEBAR

This section gives the procedure for installing the Brake Handlebar.

1. If the tractor has a Remote Air Cleaner, remove the air cleaner canister and bracket from the instrument panel.
2. Fasten the Instruction Plate and the Brake Handle Support to the rear hitch with the 1/2" x 1-3/4" bolts and 1/2" lock nuts as shown in figure 1.0-1.

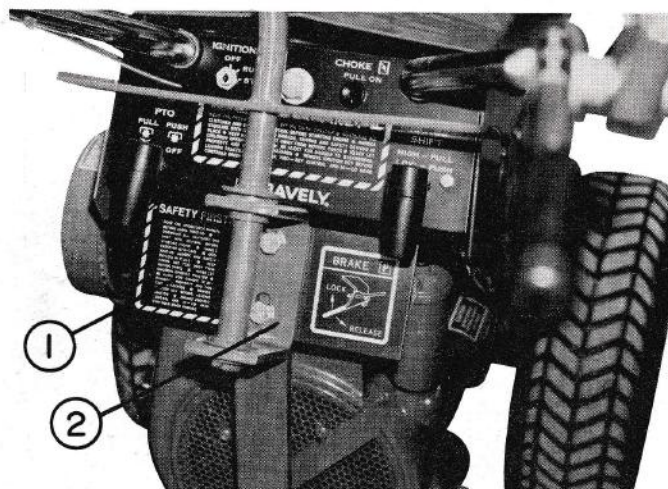

1 - Instruction Plate
2 - Brake Handle Support

Figure 1.0-1

3. Fasten the Parking Brake Handle to the Brake Handlebar with the 3/8" x 1-1/2" round head bolt, nylon washer, rubber washer, flat washer and 3/8" lock nut as shown in figure 1.0-2.

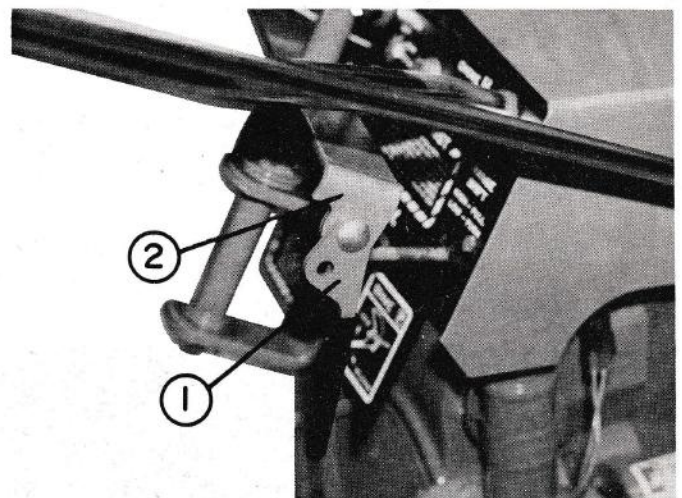

1 - Parking Brake Handle
2 - Brake Handlebar

Figure 1.0-2

To continue its program of quality and design improvement, the manufacturer reserves the right to change specifications, designs and prices without notice and incurring obligation.

Form No. 25166 (11-78)

Printed in U.S.A.

2.0 HOW TO INSTALL THE RIGHT SIDE BRAKE

This section gives the procedure for installing the right side Brake.

1. Raise the tractor wheels off the ground.
2. Remove the Axle Nut, Washer and Spacer from the axle and then remove the Wheel Assembly. See figure 2.0-1.

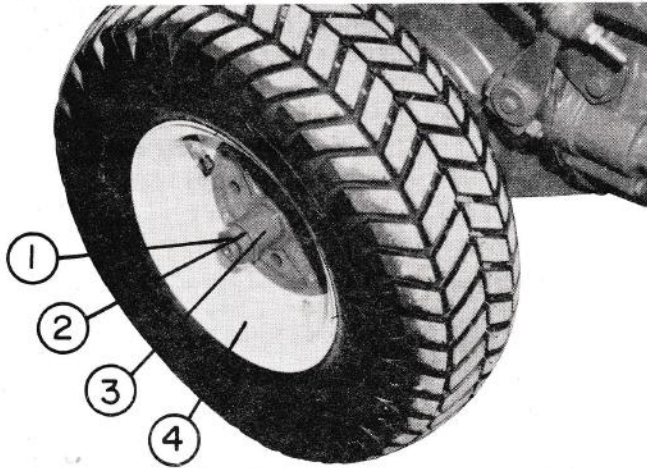

- 1 - Axle Nut
- 2 - Washer
- 3 - Spacer
- 4 - Wheel Assembly

Figure 2.0-1

If the tractor has a Range Shift, follow the procedure shown in steps 3 through 7 for the modification of the Shifter Pin.

3. Remove the Nut and Washer that holds the Shifter Arm to the Stationary Pivot shown in figure 2.0-2. Lift the Shifter Arm off the Stationary Pivot.

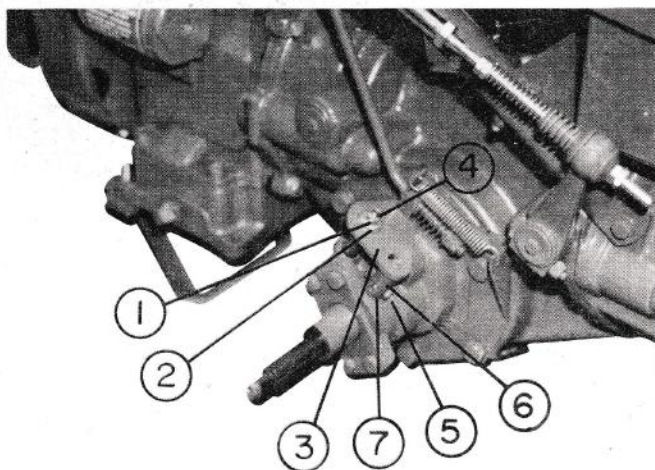

- 1 - Nut
- 2 - Washer
- 3 - Shifter Arm
- 4 - Stationary Pivot
- 5 - Bolt
- 6 - Shifter Pin
- 7 - Sliding Pin

Figure 2.0-2

4. Remove the Bolt that fastens the Shifter Pin to the Sliding Pin and remove the Shifter Pin. See figure 2.0-2.
5. Turn the Sliding Pin clockwise until tight, then turn the pin counterclockwise until the 1/4" x 2-1/4" Bolt can be put through the hole in the pin as shown in figure 2.0-3. Then put the Bushing on the Bolt.

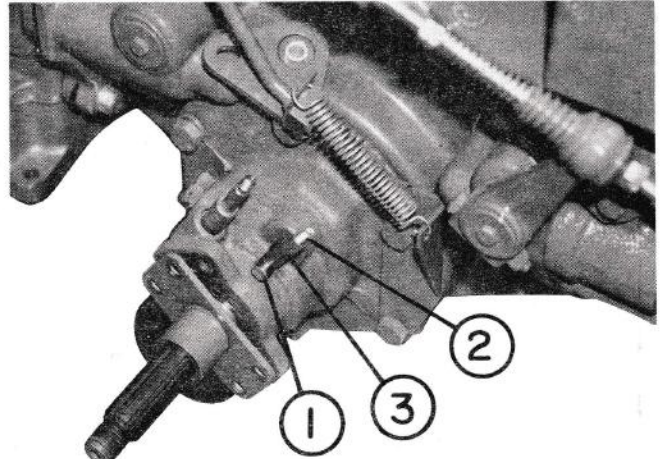

- 1 - Sliding Pin
- 2 - Bolt
- 3 - Bushing

Figure 2.0-3

6. Put the Shifter Arm on the Stationary Pivot and fasten it with the washer and nut that was removed in step 3.
7. Put two 13/16" outside diameter flat washers and one 5/8" outside diameter flat washer on the bolt that goes through the Sliding Pin and fasten with the 1/4" lock nut. Tighten the nut to a torque of 12 ft. lbs. (16 N.m).
8. Remove the four bolts from the Axle Housing End Plate as shown in figure 2.0-4.

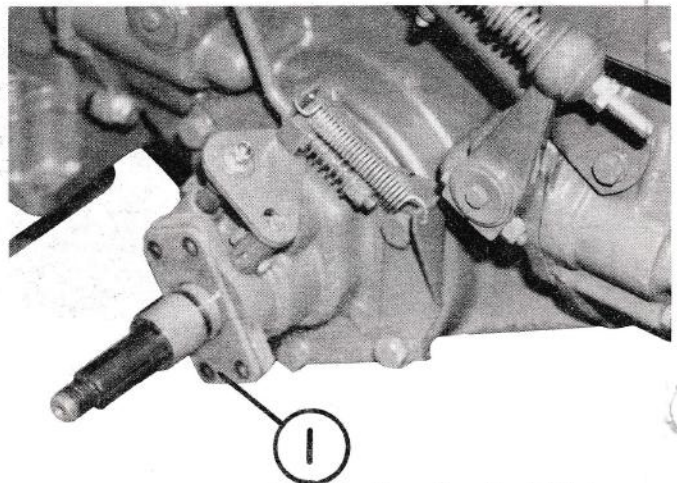

- 1 - Axle Housing End Plate

Figure 2.0-4

9. Fasten the Brake Shoe Assembly to the axle housing with the 3/8" x 5/8" Bolts as shown in figure 2.0-5.

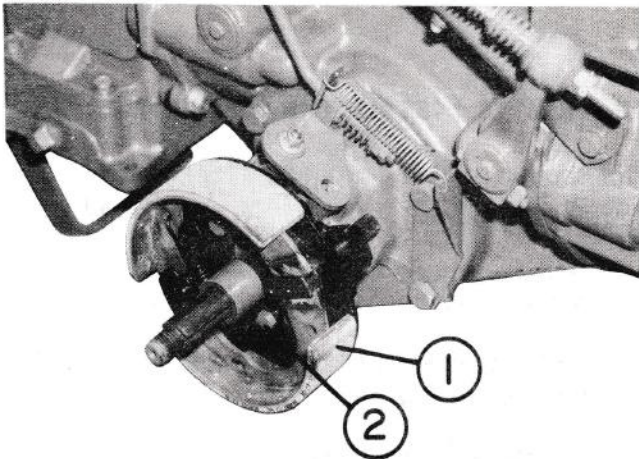

- 1 - Brake Shoe Assembly
2 - Bolt

Figure 2.0-5

10. Put the Cam Lever Arm on the Brake Cam as shown in figure 2.0-6.

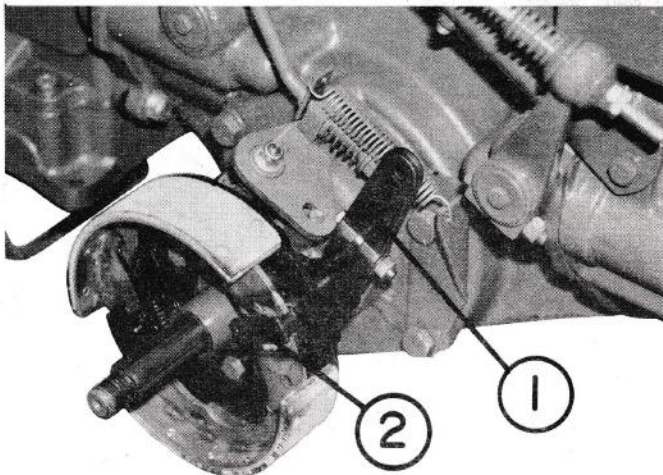

- 1 - Cam Lever Arm
2 - Brake Cam

Figure 2.0-6

11. Put the bent end of the Brake Rod in the hole in the Parking Brake Handle as shown in figure 2.0-7.

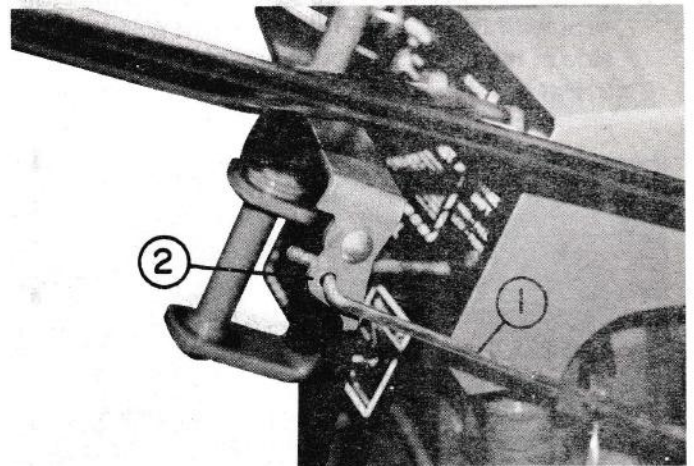

- 1 - Brake Rod
2 - Parking Brake Handle

Figure 2.0-7

12. On the other end of the Brake Rod, put two 3/8" Nuts, on the Adjusting Bracket, the Spring and two more 3/8" Nuts as shown in figure 2.0-8.

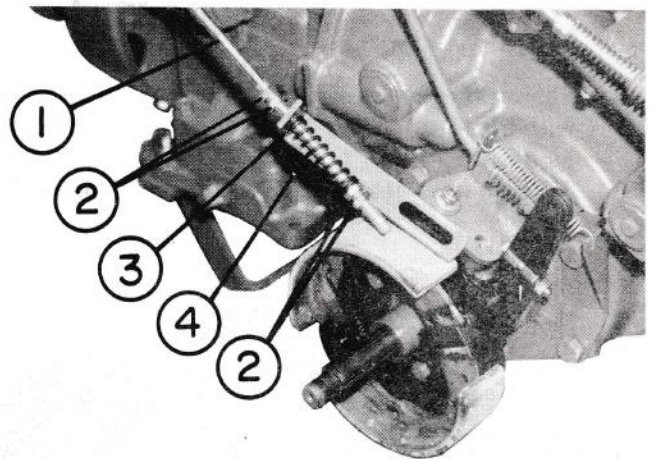

- 1 - Brake Rod
2 - Nuts
3 - Adjusting Bracket
4 - Spring

Figure 2.0-8

13. Fasten the Adjusting Bracket to the Cam Lever Arm with the Clevis Pin. Use a Flat Washer each side of the Cam Lever Arm as shown in figure 2.0-9. Put a 3/32" x 3/4" cotter pin in the Clevis Pin and separate the cotter pin ends.

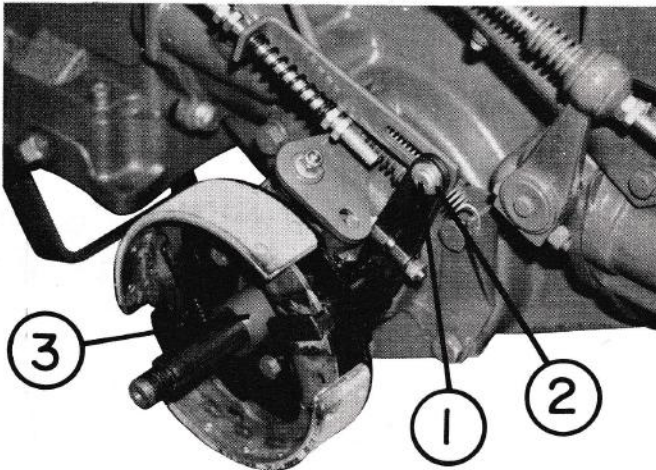

- 1 - Clevis Pin
- 2 - Flat Washer
- 3 - Spacer

Figure 2.0-9

14. Fasten the Brake Drum to the Wheel Assembly with the four 1/2" x 1-3/8" bolts and 1/2" lock nuts as shown in figure 2.0-10. If the tractor has the 8.50 x 8 tires, use the 1/2" x 1-5/8" bolts and 1/2" nuts.

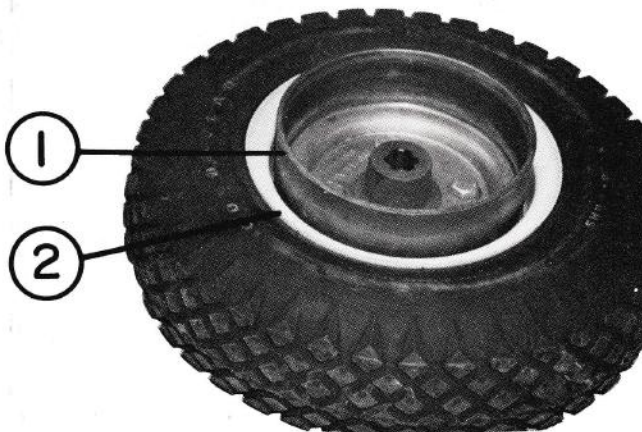

- 1 - Brake Drum
- 2 - Wheel Assembly

Figure 2.0-10

15. Put the Spacer, that was removed in step 2 of this section, on the axle as shown in figure 2.0-9.

16. Put the Wheel Assembly and the Washer on the axle and fasten with the Axle Nut. Tighten the Axle Nut to a torque of 80 ft. lbs. (108 N.m).

3.0 HOW TO INSTALL THE LEFT SIDE BRAKE

This section gives the procedure for installing the left side Brake.

1. Remove the Axle Nut, Washer and Spacer from the axle and then remove the Wheel Assembly.

To install the Pivot Stud on tractors with a battery box, follow this procedure:

- A. Remove the bolt that fastens the Tube Support to the Advance Casting and replace the bolt with the Pivot Stud as shown in figure 3.0-1.

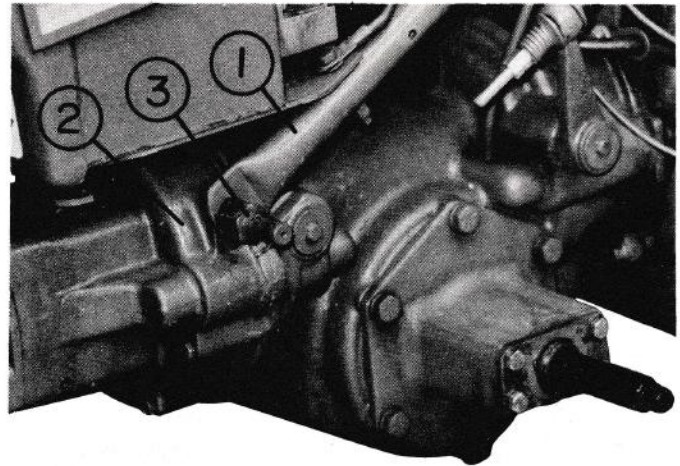

- 1 - Tube Support
- 2 - Advance Casting
- 3 - Pivot Stud

Figure 3.0-1

- B. Put an "E" ring in the center groove of the Pivot Stud.

- C. Put a flat washer on the Pivot Stud and then the Pivot Plate, a flat washer and an "E" ring in the groove as shown in figure 3.0-2.

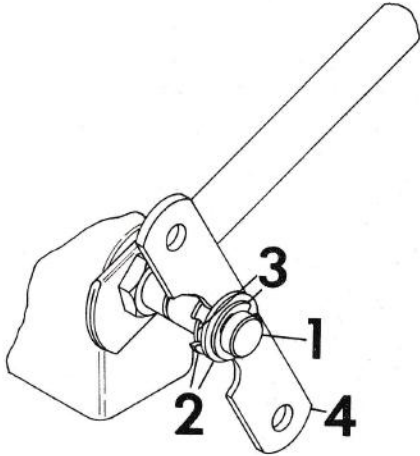

- | | |
|------------------|-----------------|
| 1 - Pivot Stud | 3 - "E" Rings |
| 2 - Flat Washers | 4 - Pivot Plate |

Figure 3.0-2

2. Put the Brake Link Rod in the hole in the Pivot Plate and fasten with a flat washer and cotter pin as shown in figure 3.0-4.

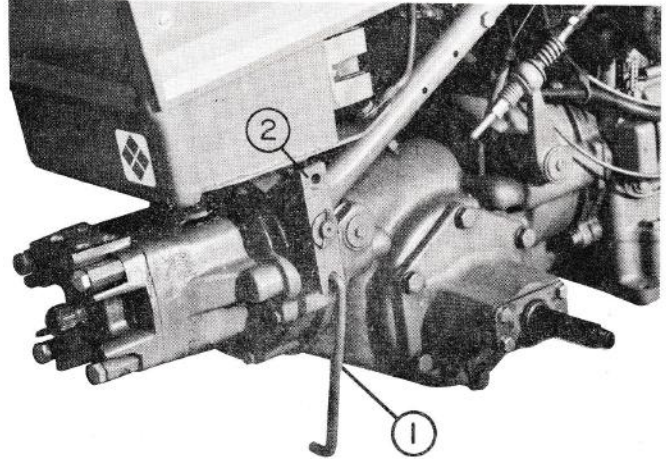

- | |
|--------------------|
| 1 - Brake Link Rod |
| 2 - Pivot Plate |

Figure 3.0-4

To install the Pivot Stud on tractors without a battery box, follow this procedure:

- A. Remove the hood stud that fastens the Tube Support to the Advance Casting and replace the hood stud with the Pivot Stud.
- B. Put the Hood on the Pivot Stud. Do not use the bushing that was in the hood.
- C. Put a flat washer on the Pivot Stud and an "E" ring in the groove next to the washer.
- D. Put an "E" ring in the center groove in the Pivot Stud.
- E. Put a flat washer on the Pivot Stud and then the Pivot Plate, a flat washer and an "E" ring in the groove as shown in figure 3.0-3.

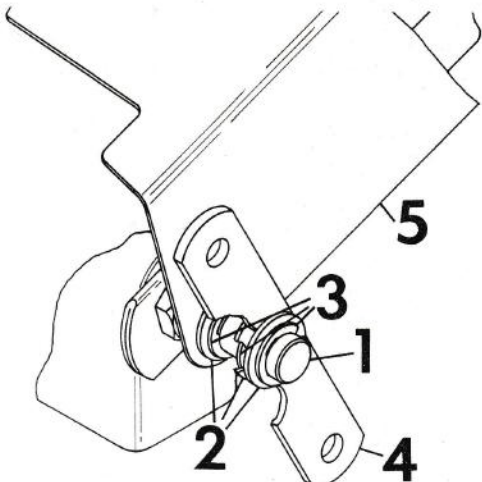

- | | |
|------------------|-----------------|
| 1 - Pivot Stud | 4 - Pivot Plate |
| 2 - Flat Washers | 5 - Hood |
| 3 - "E" Rings | |

Figure 3.0-3

3. Put the bend end of the Brake Rod in the Brake Handlebar as shown in figure 3.0-5.

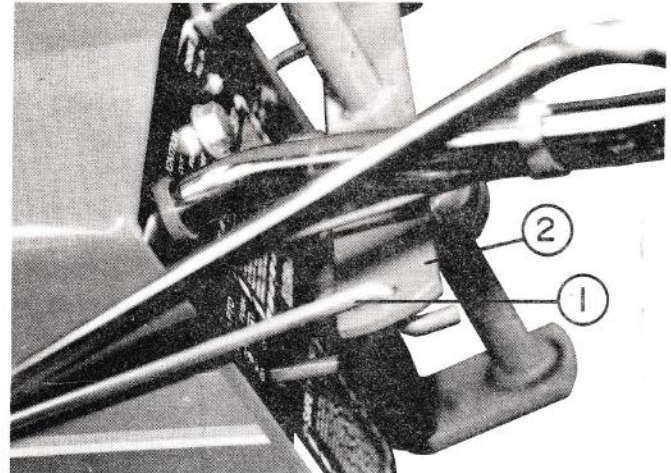

- | |
|---------------------|
| 1 - Brake Rod |
| 2 - Brake Handlebar |

Figure 3.0-5

- On the other end of the Brake Rod, put two 3/8" Nuts, the Adjustment Bracket and two more 3/8" Nuts. Fasten the Adjustment Bracket to the Pivot Plate with the flat washer and cotter pin as shown in figure 3.0-6.

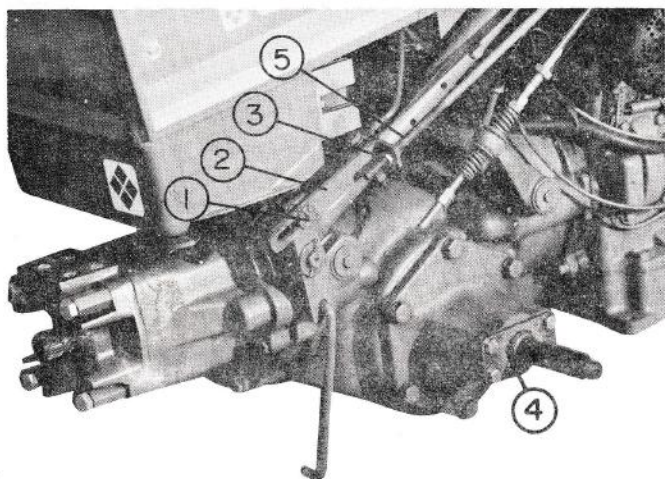

- 1 - Clevis Pin
- 2 - Adjustment Bracket
- 3 - Nuts
- 4 - End Plate
- 5 - Brake Rod

Figure 3.0-6

- Remove the four bolts from the axle housing End Plate. See figure 3.0-6.
- Fasten the Brake Shoe Assembly to the axle housing with the four 3/8" x 5/8" bolts and put the Cam Lever Arm on the Brake Cam. Then fasten the Brake Link Rod to the Cam Lever Arm with a flat washer and cotter pin as shown in figure 3.0-7.

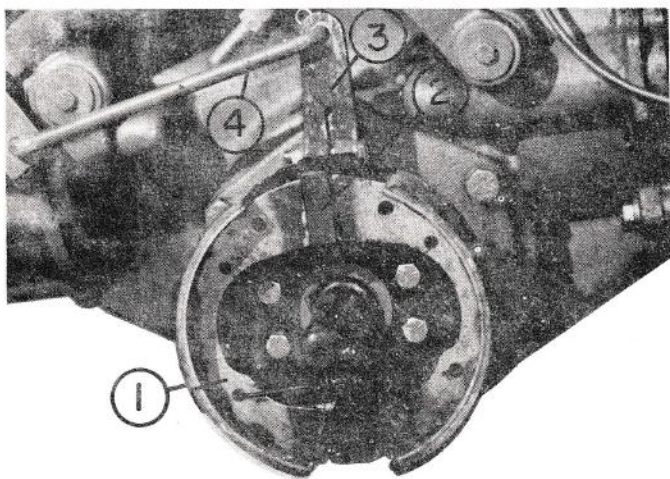

- 1 - Brake Shoe Assembly
- 2 - Brake Cam
- 3 - Cam Lever Arm
- 4 - Brake Link Rod

Figure 3.0-7

- Fasten the Brake Drum to the Wheel Assembly with the four 1/2" x 1-3/8" bolts and 1/2" lock nuts as shown in figure 2.0-10. If the tractor has the 8.50 x 8 tires, use the 1/2" x 1-5/8" bolts and 1/2" nuts.
- Put the Spacer, that was removed in step 1 of this section, on the axle.
- Put the Wheel Assembly and the Washer on the axle and fasten with the Axle Nut. Tighten the Axle Nut to a torque of 80 ft. lbs. (108 N.m).
- Lower the tractor wheels to the ground.

4.0 INSTALLING THE REMOTE AIR CLEANER CANISTER

If the tractor has a Remote Air Cleaner, fasten the air cleaner canister to the brake handlebar with the muffler clamps as shown in figure 4.0-1.



Figure 4.0-1

Be sure all air cleaner hose connections are tight to prevent dirt from going into the engine.

5.0 PROCEDURE FOR ADJUSTING THE BRAKES

This section gives the procedure for adjusting the Brakes.

- Move the tractor to level ground and stop the engine. Do not engage the Parking Brake Lock Lever.

- Loosen the jam nuts on the right and left side brake rods as shown in figures 5.0-1 and 5.0-2.

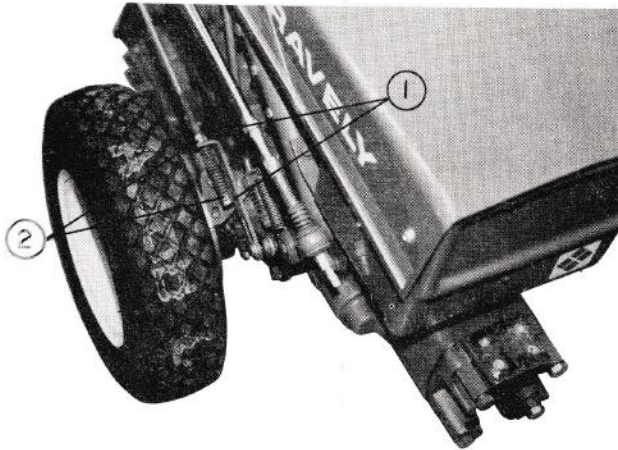

1 - Jam Nuts
2 - Adjusting Nuts

Figure 5.0-1

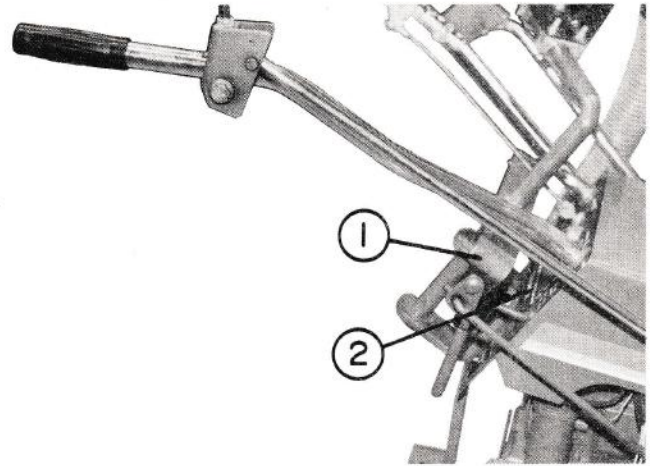

1 - Cross Bar
2 - Instrument Panel

Figure 5.0-3

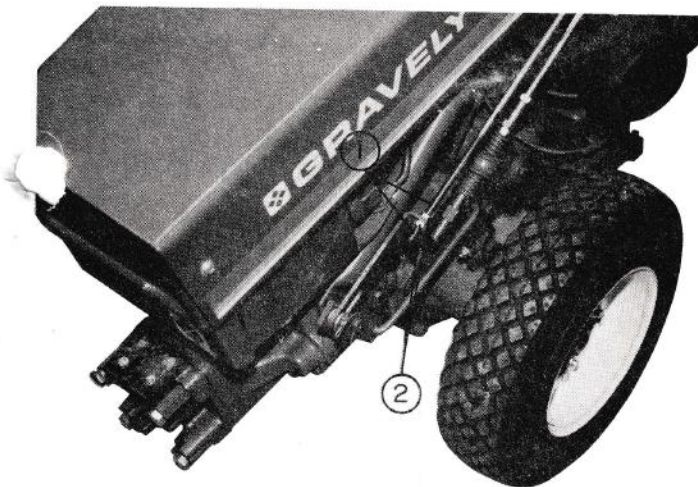

1 - Jam Nuts
2 - Adjusting Nuts

Figure 5.0-2

- Pull the Brake Handlebar all the way to the right and measure the distance from the edge of the Cross Bar to the edge of the tractor hood on the right side. Then push the Brake Handlebar all the way to the left and measure the distance from the edge of the Cross Bar to the edge of the tractor hood on the right side. The brakes will have the correct adjustment when the difference between the two measurements is 1/2" to 3/4" (13 to 19 mm).
- If the measurement is more than 1/2" to 3/4" (13 to 19 mm), turn the Adjusting Nuts clockwise and if the measurement is less, turn the nuts counterclockwise. Turn each Adjusting Nut the same amount of rotations.
- Tighten the Jam Nuts against the Adjusting Nuts.

- Turn the Adjusting Nuts on the brake rods until the Cross Bar is parallel to the Instrument Panel as shown in figure 5.0-3.

